

CROWN

SH 5500 SERIES

Specifications

Heavy-Duty Walkie
Straddle Stacker



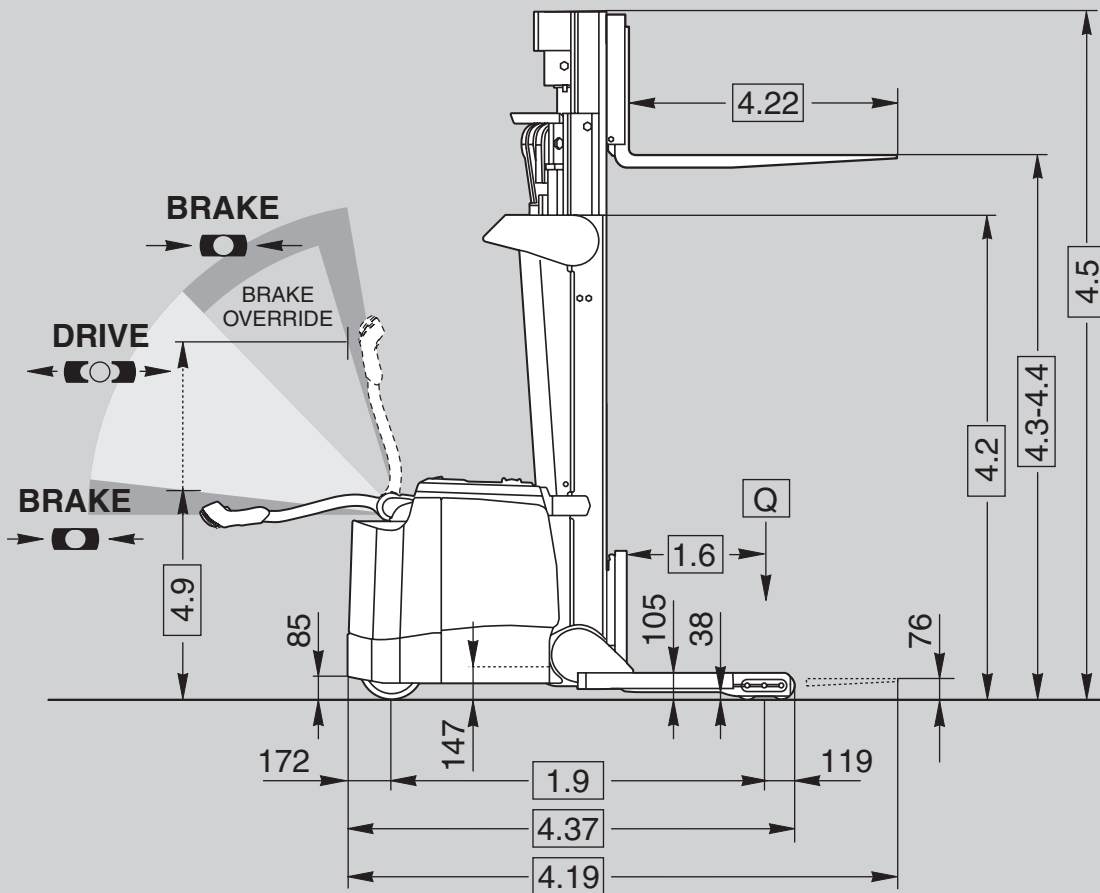
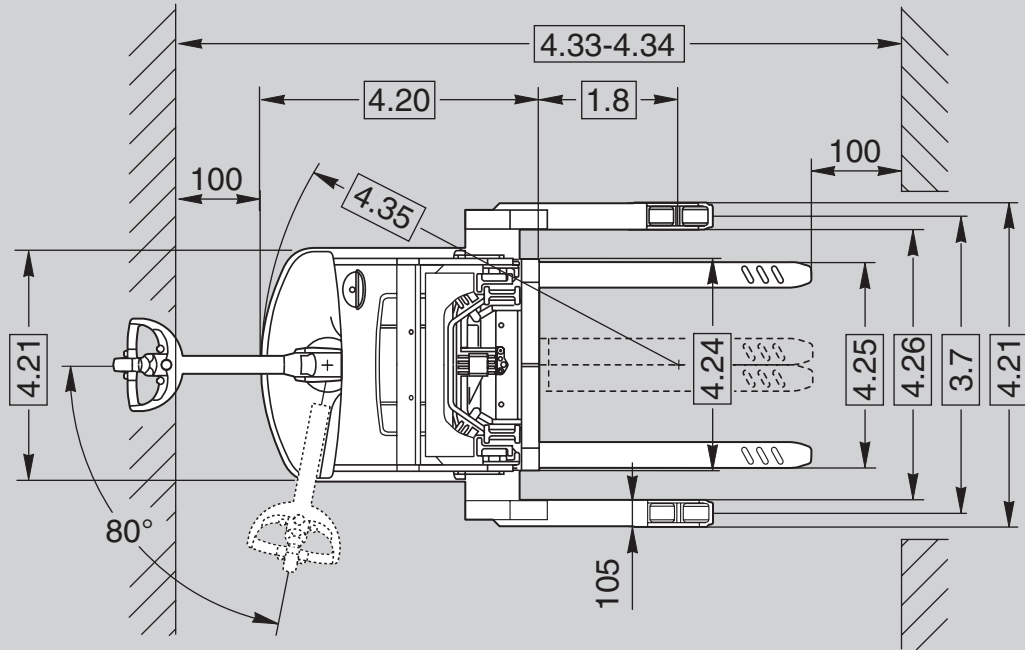

General Information	1.1	Manufacturer	Crown Equipment Corporation				
	1.2	Model			SH 5520-1.8	SH 5540-1.8	
	1.3	Power			electric		
	1.4	Operator Type			pedestrian		
	1.5	Load Capacity		Q	t	1.8	
	1.6	Load Centre		c	mm	600	
	1.8	Load Distance		x	mm	542	
	1.9	Wheel Base		y	mm	1306	1471
	Tyres	2.1	Weight	less battery		kg	see table 1
3.1		Tyre Type				Vulkollan / PU	
3.2		Wheel Size	front		mm	Ø 254 x 76	
3.3		Wheel Size	rear		mm	Ø 102 x 73	
3.5		Wheels	number (x=driven) front/rear			1x / 4	
3.6		Track Width	front	b10	mm	central position	
3.7		Track Width	rear	b11	mm	965 - 1372	
Dimensions	4.2	Mast	collapsed height	h1	mm	see table 1	
	4.3	Free Lift		h2	mm	see table 1	
	4.4	Lift Height		h3+h13	mm	see table 1	
	4.5	Mast	extended height	h4	mm	see table 1	
	4.9	Tiller Arm Height	in drive position min./max.	h14	mm	800 - 1278	
	4.10	Outrigger Height		h8	mm	105	
	4.15	Fork Height	lowered	h13	mm	76	
	4.19	Overall Length		l1	mm	2080	2245
	4.20	Headlength¹		l2	mm	935	1100
	4.21	Overall Width	front / rear	b1/b2	mm	915 / 1074- 1480	
	4.22	Fork Dimension	standard	thxwxl	mm	45 x 100 x 1145	
	4.22	Fork Dimension	optional length	l	mm	760, 915, 990, 1065, 1220, 1370, 1525	
	4.23	Fork Carriage	ISO class			2A	
	4.24	Fork Carriage Width		b3	mm	813	
	4.25	Width Across Forks		b5	mm	200 - 815	
	4.26	Inside Straddle Width	in 51 mm increments	b4	mm	863 - 1271	
	4.31	Ground Clearance	with load, below mast	m1	mm	38	
	4.32	Ground Clearance	centre wheelbase	m2	mm	53	
	4.33	Working Aisle Width	1000 x 1200 mm traverse	Ast	mm	2502	2667
4.34	Working Aisle Width	800 x 1200 mm length	Ast	mm	2517	2682	
4.35	Turning Radius		Wa	mm	1547	1712	
4.37	Length Over Outriggers		l7	mm	1597	1762	
Performance	5.1	Travel Speed	w. / w.o. load		km/h	5.5 / 6	
	5.2	Lift Speed	w. / w.o. load		m/s	0.15 / 0.24	
	5.3	Lowering Speed	w. / w.o. load		m/s	0.25 / 0.25	
	5.7	Gradeability	w. / w.o. load, 30 min. rating		%	4 / 8	
	5.8	Max. Gradeability	w. / w.o. load, 5 min. rating		%	10 / 10	
	5.10	Service Brake				electromagnetic	
Motors	6.1	Traction Motor	rating at S2 60 min.		kW	2.0	
	6.2	Lift Motor	rating at S3 15%		kW	3.3	
	6.3	Max. Battery Compartment Size		lxwxh	mm	168 x 778 x 630	333 x 801 x 630
	6.4	Battery Voltage	nominal capacity K5		V / Ah	24 / 225	24 / 525
	6.5	Battery Weight	minimum		kg	230	442
8.1	Type Controller	drive			transistor		

Table 1					SH 5520-1.8			SH 5540-1.8			
					TL		TT	TL		TT	
2.1	Weight	less battery		kg	1370	1420	1620	1290	1335	1535	1640
4.2	Mast	collapsed height	h1	mm	2125	2430	1905	2125	2430	1905	2265
4.3	Free Lift²		h2	mm	150	150	1335	150	150	1335	1690
4.4	Lift Height		h3+h13	mm	3225	3810	3960⁴	3225	3810	3960⁴	4875⁵
4.5	Mast³	extended height	h4	mm	3810	4395	4535	3810	4395	4535	5450

¹ Add 55 mm for side shift

² Subtract 625 mm on all TT masts with optional load backrest

³ Add 630 mm to all masts with optional load backrest

⁴ Minimum inside straddle width is 965 mm

⁵ Minimum inside straddle width is 1067 mm, load capacity 1.8 t up to 3960 mm, 1.35 t at 4875 mm

Standard Equipment

1. 24-volt electrical system
2. Crown's Access 1 2 3® Comprehensive System Control
3. Crown's Access 1 2 3 information display
 - 1 line display with 8 characters
 - Scrolling function via 5 button access
 - Three selectable performance levels
 - BDI with lift interrupt
 - Five hour meters
 - Event codes
 - Access 1 2 3 onboard diagnostics with real time troubleshooting capability
 - PIN code capability
4. AC traction and steer motors
5. Performance enhancing features
 - X10® Handle
 - Brake override
 - Electronic power steering
 - Ramp hold and speed control
 - Power boost
 - High-visibility mast and carriage
 - Low profile power unit
 - Tool storage tray
6. Metal mast grill
7. Volkollan drive tyre
Ø 254 x 76 mm
8. Polyurethane load wheels
Ø 102 x 73 mm
9. InfoPoint® System
10. Steel power unit covers
11. Electric power disconnect plug
12. Key switch
13. Horn
14. SBE160 red battery connector
15. Reversing button
16. Electric park brake
17. Fork tip indicators
18. Battery compartment rollers

Optional Equipment

1. 30 amp on-board charger only for the small battery compartment
2. Work Assist™ Accessories:
 - Clip pad
 - Hook
 - Clip pad and hook
 - Pocket
3. Sideshifter
4. 1195 mm high load backrest
5. Optional fork lengths
6. Freezer conditioning
7. Plexiglass mast guard
8. Ø 254 x 102 mm drive tyre
 - Soft poly
 - Siped soft poly
9. InfoLink® ready
10. Travel Alarm
11. Flashing amber light or mast mounted spotlight
12. Special paint
13. Lift limit switch

Operator Controls

Crown's robust X10 handle places all control buttons in the optimum position for ease of operation with either hand and to minimise hand and wrist movements.

An ergonomic forward/reverse thumb wheel allows for precise manoeuvring. The control hand grips are urethane covered for insulation from cold and vibration with integrated horn buttons for easy activation. The handle contains a safety button which reverses the direction of the truck should the button touch the operator. The physical effort to hold the handle at a comfortable height was minimised to reduce fatigue.

A rabbit/turtle switch incorporates two levels of programmable travel performance so operators can select the setting that matches their experience level or application requirements.

Exclusive brake override feature allows slow speed travel with the handle near vertical. This feature improves manoeuvrability in tight areas.

Performance

The SH 5500 Series incorporates the latest generation AC drive system enhanced with Access 1 2 3 technology. Crown's Access 1 2 3 technology continuously monitors truck systems and adjusts system parameters to deliver optimum performance and control. The Access Display provides a convenient interface for operators keeping them informed of any changes impacting truck performance and allowing them to choose from three performance profiles when enabled.

Programmable performance settings enable authorised personnel to tune the lift truck to different operator skill levels, or to meet specific application requirements. In addition, up to 25 PIN codes can be assigned to individual operators and matched to one of the pre-programmed performance profiles if desired.

Electronic power steering allows the operator to manoeuvre heavy loads in tight spaces throughout the day while minimising fatigue. Smooth travel and lift performance combine with excellent controls provided by the X10 handle to increase productivity.

The SH 5500 Series features ramp hold and speed control to improve operation on small inclines or ramps. The ramp hold feature uses the motor to prevent truck movement

when the brake is released and no travel command is present. The ramp speed control feature ensures that actual travel speed matches requested travel speed. If the truck encounters an obstacle, a power boost feature delivers up to 15 percent more power than normally available for a full three seconds to overcome the obstruction.

Electrical System

A heavy-duty 24-volt fused electrical system utilises microprocessor controls for maximum energy efficiency, reduced maintenance and infinite speed control capability. Access control modules for travel, lift and steer are sealed from dirt, dust and moisture for trouble-free operation. All contactors have been eliminated except for the main line contactor. A SBE 160 red battery connector with disconnect handle is standard.

Hydraulic System

Heavy-duty hydraulic motor (3.3 kW) is transistor controlled and matched with a gear type pump selected for optimum lift performance and low noise. Single-speed lift with programmable acceleration – deceleration and programmable two-speed lowering enables customisation to match operator preference or application requirements. Cylinder rods are hard-plated chrome with polyurethane seals. Relief valve tuned to capacity protects all components in the hydraulic system. Reservoir incorporates an in-tank 10 micron return filter for removing debris from oil.

Drive Unit / Brake

Heavy-duty gearbox with helical spur input gear for quiet operation. Regenerative motor braking is activated under a downhill condition, during plugging or when the directional control is returned to neutral. An electro-magnetic brake, spring applied and electrically released, is mounted on top of the drive motor. The electro-magnetic brake serves as the parking brake and applies when the control handle position moves from the operating zone to brake zone during truck operation.

Power Steering

Electronic power steering is provided by a heavy-duty AC motor that pivots the drive unit when steer tiller movement is detected.

Mast

High visibility two and three-stage mast design with angled cross bracing and lift cylinders located behind nested I-beams provides maximum visibility for load positioning and placement. Crown's staging cushions coupled with lowering dampers ensure smooth operation. Rolled steel outer mast channels and inner I-beams roll on canted, steel, anti-friction roller bearings for minimal current draw and long life. Mast and chain rollers are sealed and lubricated for life. Telescoping mast sections nest to reduce truck length. Heavier mast cross bracing design increases stiffness.

Serviceability / Durability

The Access display simplifies service for technicians by providing advanced diagnostics without the need for separate handsets. The display allows the technician to view event service codes and truck hours when event occurred, perform system calibrations or functional tests of components, and make necessary adjustments. Crown's InfoPoint System compliments Access 1 2 3 diagnostics with on-truck component maps and information nudgets to further simplify troubleshooting. Removable steel power unit doors are hinged for ease of opening providing excellent accessibility to the distribution panel and all other components. Steel covers provide added protection to critical internal components. Removable steel battery covers and hinged cover allow easy access to the battery. Battery removal can be accomplished from either side. Battery compartment rollers are standard. The X10 handle incorporates a vacuum die cast process using high-grade aluminium and benefits from structural webbing for maximum strength and durability.

Safety Regulations

Conforms to European safety standards. Dimensions and performance data given may vary due to manufacturing tolerances. Performance is based on an average size vehicle and is affected by weight, condition of truck, how it is equipped and the conditions of the operating area. Crown products and specifications are subject to change without notice.

